4-Channel Audio Processor IC

PT2313**Description**

PT2313 is an four-channel digital audio processor utilizing CMOS Technology. Volume, Right/Left Bass and Treble Balance, Front/Rear Fader Processor are incorporated into a single chip. Loudness Function and Selectable Input Gain are also provided to build a highly effective electronic audio processor having the highest performance and reliability with the least external components. All functions are programmable using the Serial Bus. The pin assignments and application circuit are optimized for easy PCB layout and cost saving advantage for audio application. PT2313 is housed in a 28-pin DIP/SO Package and is functionally compatible with TDA7313.

Features

- CMOS Technology
- Least External Components
- Treble and Bass Control
- Loudness Function
- 3 Stereo Inputs with Selectable Input Gain
- Input/Output for External Noise Reduction System/Equalizer
- 4 Independent Speaker Controls for Fader and Balance
- Independent Mute Function
- Volume Control in 1.25 dB/step
- Low Distortion
- Low Noise and DC Stepping
- Controlled by Serial Bus Micro-Processor Interface

Applications

- Car Stereo (Audio)
- Hi-Fi Audio System

4-Channel Audio Processor IC

PT2313

Block Diagram

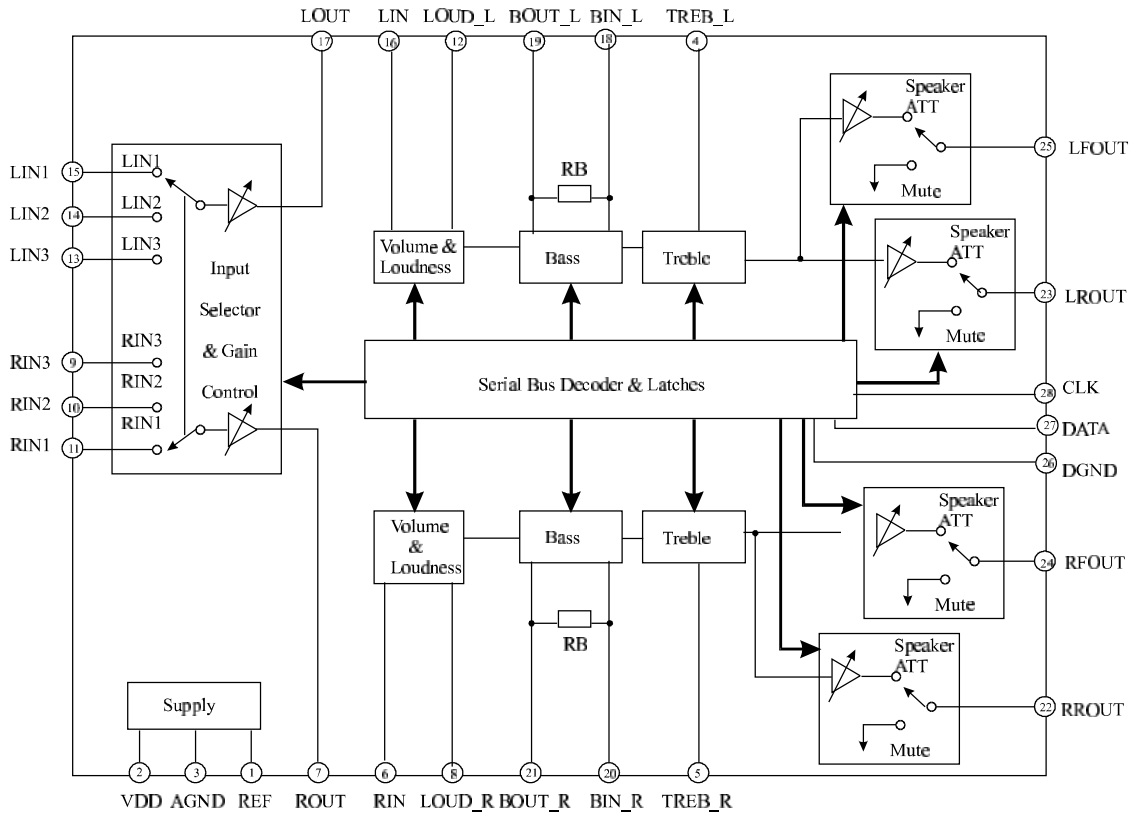

Pin Configuration

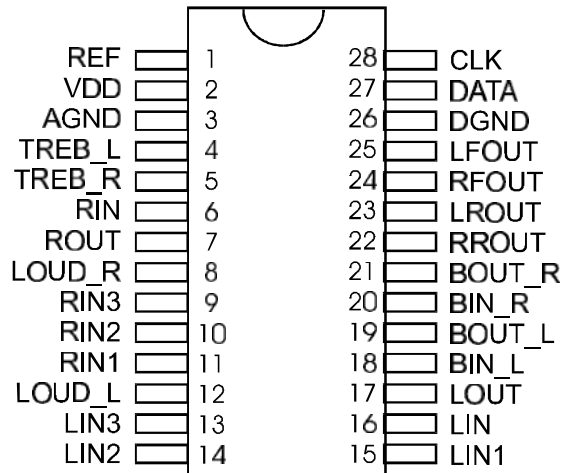

PT2313

4-Channel Audio Processor IC**PT2313****Pin Description**

Pin Name	I/O	Description	Pin No.
REF	-	Analog Reference Voltage (1/2 VDD)	1
VDD	-	Supply Input Voltage	2
AGND	-	Analog Ground	3
TREB_L	I	Left Channel Input for Treble Controller	4
TREB_R	I	Right Channel Input for Treble Controller	5
RIN	I	Audio Processor Right Channel Input	6
ROUT	O	Gain Output and Input Selector for Right Channel	7
LOUD_R	I	Right Channel Loudness Input	8
RIN3	I	Right Channel Input 3	9
RIN2	I	Right Channel Input 2	10
RIN1	I	Right Channel Input 1	11
LOUD_L	I	Left Channel Loudness Input	12
LIN3	I	Left Channel Input 3	13
LIN2	I	Left Channel Input 2	14
LIN1	I	Left Channel Input 1	15
LIN	I	Audio Processor Left Channel Input	16
LOUT	O	Gain Output and Input Selector for Left Channel	17
BIN_L	I	Left Bass Controller Input Channel	18
BOUT_L	O	Left Bass Controller Output Channel	19
BIN_R	I	Right Channel Input for Bass Controller	20
BOUT_R	O	Right Channel Output for Bass Controller	21
RROUT	O	Right Rear Speaker Output	22
LROUT	O	Left Rear Speaker Output	23
RFOUT	O	Right Front Speaker Output	24
LFOUT	O	Left Front Speaker Output	25
DGND	-	Digital Ground	26
DATA	I	Control Data Input	27
CLK	I	Clock Input for Serial Data Transmission	28

4-Channel Audio Processor IC

PT2313

Functional Description

Bus Interface

Data are transmitted to and from the microprocessor to the PT2313 via the DATA and CLK. The DATA and CLK make up the BUS Interface. It should be noted that the pull-up resistors must be connected to the positive supply voltage.

Data Validity

A data on the DATA Line is considered valid and stable only when the CLK Signal is in HIGH State. The HIGH and LOW State of the DATA Line can only change when the CLK signal is LOW. Please refer to the figure below.

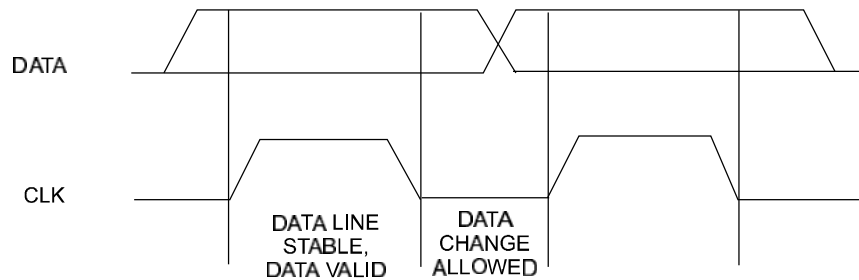

Start and Stop Conditions

A Start Condition is activated when 1) the CLK is set to HIGH and 2) DATA shifts from HIGH to LOW State. The Stop Condition is activated when 1) CLK is set to HIGH and 2) DATA shifts from LOW to HIGH State. Please refer to the timing diagram below.

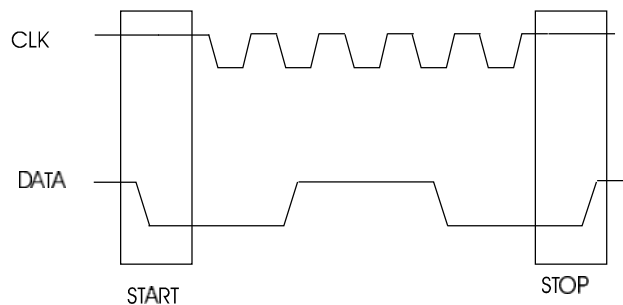

4-Channel Audio Processor IC

PT2313***Byte Format***

Every byte transmitted to the DATA Line consist of 8 bits. Each byte must be followed by an Acknowledge Bit. The MSB is transmitted first.

Acknowledge

During the Acknowledge Clock Pulse, the master (P) puts a resistive HIGH level on the DATA Line. The peripheral (audio processor) that acknowledges has to pull-down (LOW) the DATA line during the Acknowledge Clock Pulse so that the DATA Line is in a Stable Low State during this Clock Pulse. Please refer to the diagram below.

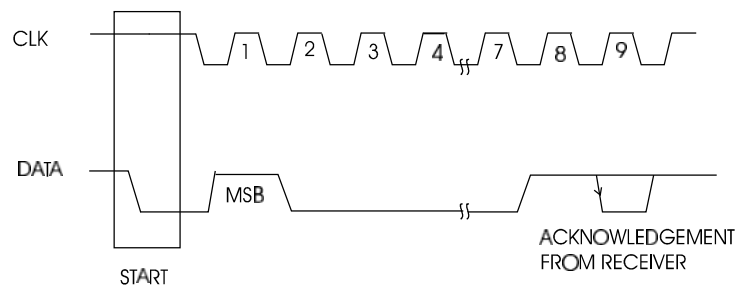

The audio processor that has been addressed has to generate an acknowledge after receiving each byte, otherwise, the DATA Line will remain at the High Level during the ninth (9th) Clock Pulse. In this case, the master transmitter can generate the STOP Information in order to abort the transfer.

Transmission without Acknowledge

If you want to avoid the acknowledge detection of the audio processor, a simpler P transmission may be used. Wait one clock and do not check the slave acknowledge of this same clock then send the new data. If you use this approach, there are greater chances of faulty operation as well as decrease in noise immunity.

Interface Protocol

The interface protocol consists of the following:

- A Start Condition
- A Chip Address Byte including the PT2313 address. The 8th Bit of the Byte must be "0". PT2313 must always acknowledge the end of each transmitted byte.

4-Channel Audio Processor IC

PT2313

- A Data Sequence (N-Bytes + Acknowledge)
- A Stop Condition

Please refer to the diagram below:

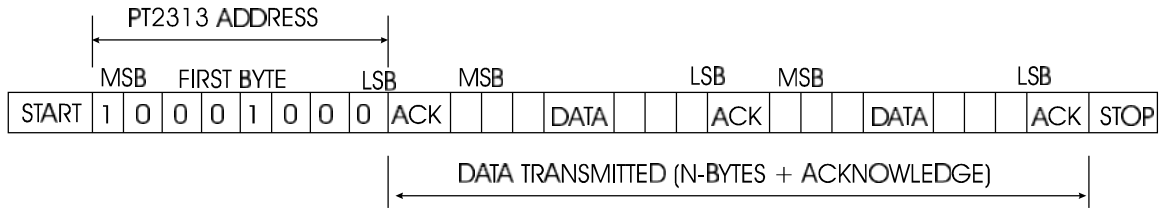

Note: ACK = ACKNOWLEDGE
 MAX. CLOCK SPEED = 100KBITS/S

Software Specification

PT2313 Address

PT2313 Address is shown below.

1	0	0	0	1	0	0	0
MSB							LSB

Data Bytes

MSB							LSB	FUNCTION
0	0	B2	B1	B0	A2	A1	A0	Volume Control
1	1	0	B1	B0	A2	A1	A0	Speaker ATT LR
1	1	1	B1	B0	A2	A1	A0	Speaker ATT RR
1	0	0	B1	B0	A2	A1	A0	Speaker ATT LF
1	0	1	B1	B0	A2	A1	A0	Speaker ATT RF
0	1	0	G1	G0	S2	S1	S0	Audio Switch
0	1	1	0	C3	C2	C1	C0	Bass Control
0	1	1	1	C3	C2	C1	C0	Treble Control

where Ax = 1.25 dB steps; Bx = 10 dB steps; Cx = 2 dB steps; Gx = 3.75 dB/steps

4-Channel Audio Processor IC

PT2313

Volume

The table below gives a detailed description of the Volume Data Bytes. For example, a volume of -37.5 dB is given by 0 0 0 1 1 1 0.

MSB							LSB	FUNCTION
0	0	B2	B1	B0	A2	A1	A0	Volume 1.25 dB steps
					0	0	0	0
					0	0	1	-1.25
					0	1	0	-2.5
					0	1	1	-3.75
					1	0	0	-5
					1	0	1	-6.25
					1	1	0	-7.5
					1	1	1	-8.75
0	0	B2	B1	B0	A2	A1	A0	Volume 10dB steps
		0	0	0				0
		0	0	1				-10
		0	1	0				-20
		0	1	1				-30
		1	0	0				-40
		1	0	1				-50
		1	1	0				-60
		1	1	1				-70

Speaker Attenuators

The table below gives a detailed description of the speaker attenuators data bytes. For example, an attenuation of 30dB on the Speaker LF (Right Front) is given by: 1 0 0 1 1 0 0 0.

MSB							LSB	FUNCTION
1	0	0	B1	B0	A2	A1	A0	Speaker LF
1	0	1	B1	B0	A2	A1	A0	Speaker RF
1	1	0	B1	B0	A2	A1	A0	Speaker LR
1	1	1	B1	B0	A2	A1	A0	Speaker RR
					0	0	0	0
					0	0	1	-1.25
					0	1	0	-2.5
					0	1	1	-3.75

4-Channel Audio Processor IC

PT2313

					1	0	0	-5
					1	0	1	-6.25
					1	1	0	-7.5
					1	1	1	-8.75
			0	0				0
			0	1				-10
			1	0				-20
			1	1				-30
			1	1	1	1	1	Mute

Audio Switch Data Byte

The following table shows the detailed description of the Audio Switch Data Bytes. For example, a Stereo 1 Input with Gain of +11.25 dB Loudness ON is given by: 0 1 0 0 0 0 0 0.

MSB							LSB	FUNCTION
0	1	0	G1	G0	S2	S1	S0	Audio Switch
						0	0	Stereo 1
						0	1	Stereo 2
						1	0	Stereo 3
						1	1	Stereo 4 *
					0			Loudness ON
					1			Loudness OFF
			0	0				+11.25dB
			0	1				+7.5dB
			1	0				3.75dB
			1	1				0dB

Note: * = Stereo 4 is internally connected.

Bass and Treble Data Bytes

The following table shows a detailed description of the Bass and Treble Data Byte. For example a Treble at -12dB is given by : 0 1 1 1 0 0 0 1.

4-Channel Audio Processor IC

PT2313

MSB							LSB	Function
0	1	1	0	C3	C2	C1	C0	Bass
0	1	1	1	C3	C2	C1	C0	Treble
				0	0	0	0	-14
				0	0	0	1	-12
				0	0	1	0	-10
				0	0	1	1	-8
				0	1	0	0	-6
				0	1	0	1	-4
				0	1	1	0	-2
				0	1	1	1	0
				1	1	1	1	0
				1	1	1	0	2
				1	1	0	1	4
				1	1	0	0	6
				1	0	1	1	8
				1	0	1	0	10
				1	0	0	1	12
				1	0	0	0	14

Unit: dB

Thermal Data

Symbol	Description	SO28	DIP28	Unit
Rth j-pins	Thermal Resistance Junction-Pins Max.	85	65	°C/W

Absolute Maximum Ratings

Symbol	Parameter	Rating	Unit
Vs	Operating Supply Voltage	10.2	V
Tamb	Operating Ambient Temperature	-40 to 85	°C
Tstg	Storage Temperature Range	-55 to +150	°C

4-Channel Audio Processor IC

PT2313

Quick Reference Data

Symbol	Parameter	Min.	Typ.	Max.	Unit
V _s	Supply Voltage	6	9	10	V
V _{CL}	Max. Input Signal Handling	2			V _{rms}
THD	Total harmonic Distortion V = 1V _{rms} , f = 1KHz		0.01	0.1	%
S/N	Signal to Noise ratio		106		dB
Sc	Channel Separation f = 1KHz		103		dB
	Volume Control 1.25dB step	-78.75		0	dB
	Bass & Treble Control 2dB step	-14		+14	dB
	Fader & Balance Control 1.25dB step	-38.75		0	dB
	Input Gain 3.75 dB step	0		11.25	dB
	Mute Attenuation		100		dB

Electrical Characteristics

(Unless specified: T_{amb} = 25°C, V_c=9V, R_L=10KΩ, R_g = 600Ω, all controls flat (G=0), f=1KHz)

Symbol	Parameter	Test Condition	Min.	Typ.	Max.	Unit
Supply						
V _{cc}	Supply Voltage		6	9	10	V
I _s	Supply Current			8	11	mA
SVRR	Ripple Rejection		60	80		dB
Input Selectors						
R _{II}	Input Resistance	Input 1,2,3	35	50	70	KOhms
V _{CL}	Clipping Level		2	2.5		V _{rms}
S _{IN}	Input Separation (2)		80	100		dB
R _L	Output Load Resistance	Pin 7, 17	2			KOhms
G _{INmin}	Min. Input Gain		-1	0	1	dB
G _{INmax}	Max. Input Gain			11.25		dB
G _{STEP}	Step Resolution			3.75		dB
E _{in}	Input Noise	G=11.25dB		2		uV
V _{DC}	DC Steps	Adjacent Gain Steps		4	20	mV
		G=18.75 dB to Mute		4		mV

4-Channel Audio Processor IC

PT2313

Volume Control						
R_{IV}	Input Resistance		20	33	50	KOhms
C_{RANGE}	Control Range		70	75	80	dB
A_{VMIN}	Min. Attenuation		-1	0	1	dB
A_{VMAX}	Max. Attenuation		70	75	80	dB
A_{STEP}	Step Resolution		0.5	1.25	1.75	dB
E_A	Attenuation Set Error	AV=0 to -20dB	-1.25	0	1.25	dB
		AV=-20 to -60dB	-3		2	dB
E_T	Tracking Error				2	dB
V_{DC}	DC Steps	Adjacent Attenuation Steps From 0dB to AV max		0	3	mV
				0.5	7.5	mV
Speaker Attenuators						
C_{RANGE}	Control Range		35	37.5	40	dB
S_{STEP}	Step Resolution		0.5	1.25	1.75	dB
E_A	Attenuation Set Error				1.5	dB
A_{MUTE}	Output Mute Attenuation		80	100		dB
V_{DC}	DC Steps	Adjacent Att. Steps From 0 to Mute		0	3	mV
				1	10	mV
Bass Control (1)						
G_b	Control Range	Max. Boost/Cut	± 12	± 14	± 16	dB
B_{STEP}	Step Resolution		1	2	3	dB
R_B	Internal Feedback Resistance		34	44	58	KOhms
Treble Control (1)						
G_t	Control Range	Max. Boost/Cut	± 13	± 14	± 15	dB
T_{STEP}	Step Resolution		1	2	3	dB
Audio Outputs						
V_{OCL}	Clipping Level	d=0.3%	2	2.5		Vrms
R_L	Output Load Resistance		2			KOhms
C_L	Output Load Capacitance				10	nF
R_{OUT}	Output Resistance		30	75	120	Ohms
V_{OUT}	DC Voltage Level		4.2	4.5	4.8	V

4-Channel Audio Processor IC

PT2313

General						
e _{NO}	Output Noise	BW==20-20KHz, flat		2.5		uV
		Output Muted		5	15	uV
		All gains=0dB				
		A Curve All Gains=0dB		3		uV
S/N	Signal to Noise Ratio	All Gains=0dB		106		dB
d	Distortion	V _o =1Vrms				
		AV=0, V _{IN} =1Vrms		0.01	0.1	%
		AV=-20dB, V _{IN} =1Vrms		0.09	0.3	%
		V _{IN} =0.3Vrms		0.04		%
Sc	Channel Separation Left/Right		80	103		dB
	Total Tracking Error	AV=0 to -20dB		0	1	dB
		-20 to -60dB		0	2	dB
Bus Inputs						
V _{IL}	Input Low Voltage				1	V
V _{IH}	Input High Voltage		3			V
I _{IN}	Input Current		-5		+5	uA
V _o	Output Voltage SDA Acknowledge	I _o =1.6mA			0.4	V

Note: (1) For the Bass and Treble response please, refer to the diagram below. The center frequency and quality of the resonance behavior can be selected by the external circuitry. A standard first order bass response can realized by a standard feedback network.

(2) The selected input is grounded thru the 2.2uF capacitor.

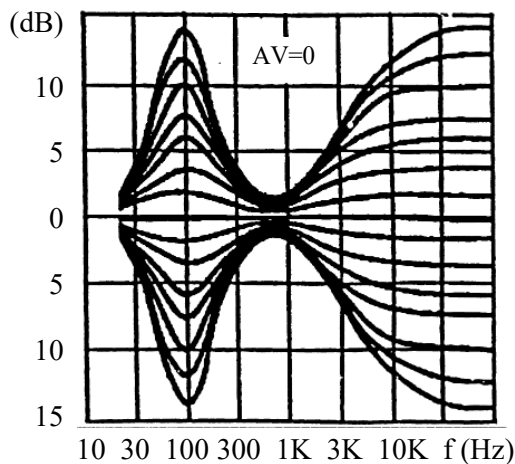

Typical Tone Response (with the ext. Components indicated in the test circuit)

4-Channel Audio Processor IC

PT2313

Loudness vs Volume Attenuation

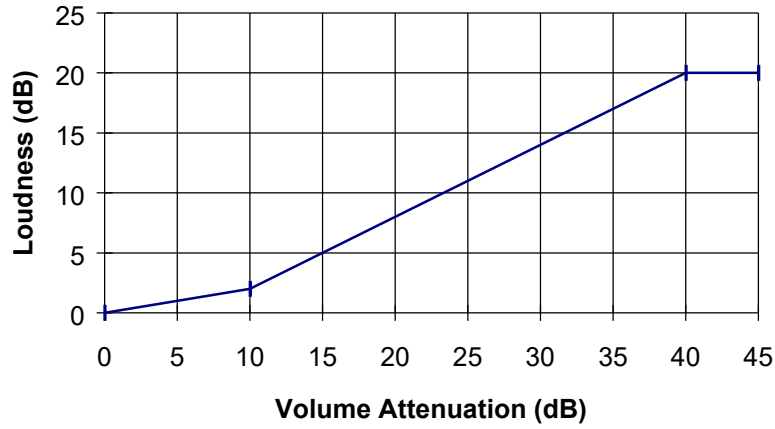

Quiescent Current vs. Supply Voltage

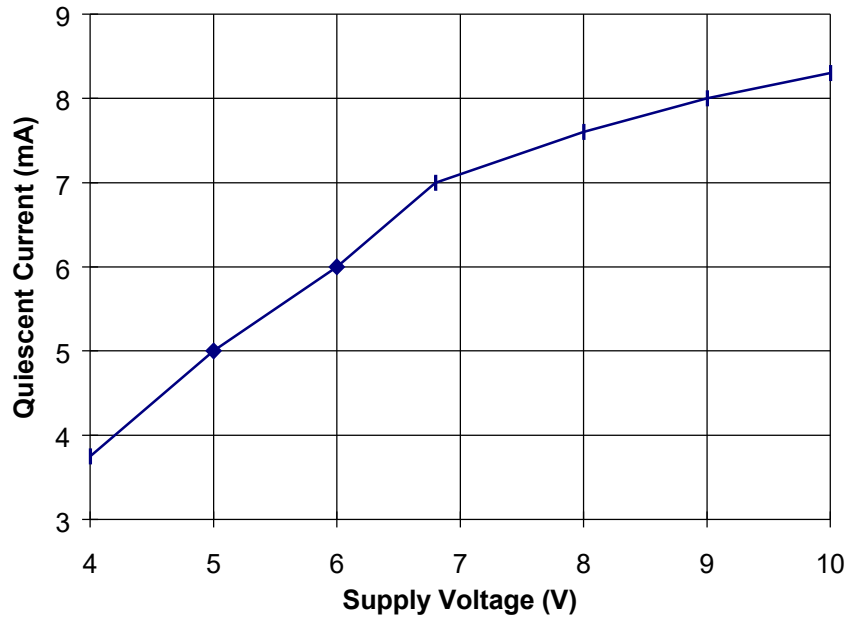

4-Channel Audio Processor IC

PT2313

Application Circuit

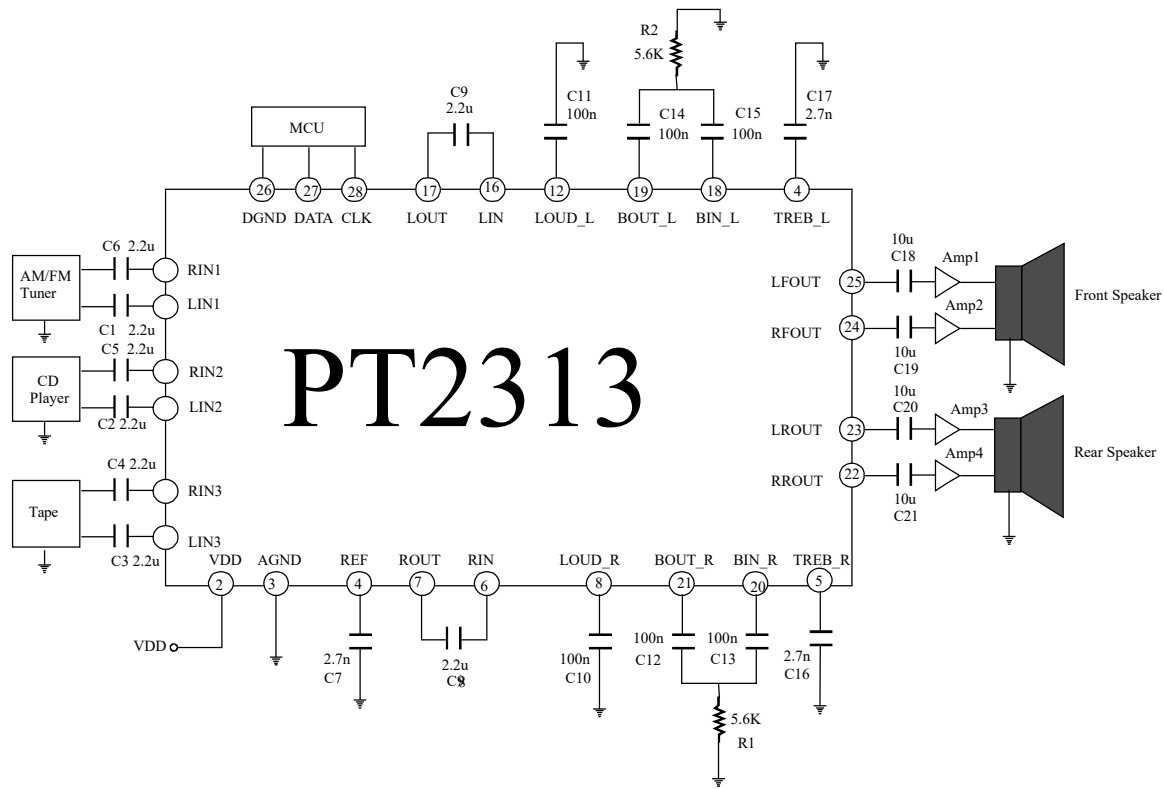

Order Information

Valid Part Number	Package Type
PT2313	28 Pins, DIP
PT2313-S	28 Pins, SO (300 mil)

4-Channel Audio Processor IC

PT2313

Package Information

28 Pins, DIP Package

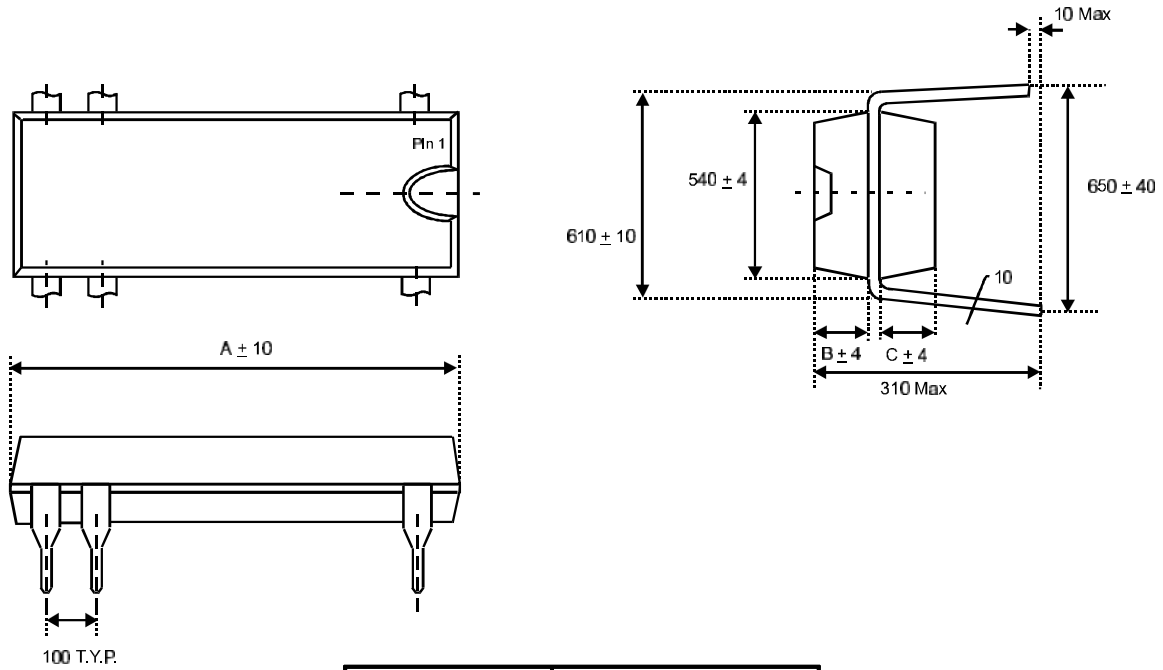

Symbol	Dimension in Mil
A	1450
B	70
C	70

4-Channel Audio Processor IC

PT2313

28 Pins, SO Package (300 mil)

Bottom E-Pin Indent ϕ 0.125 Note 8

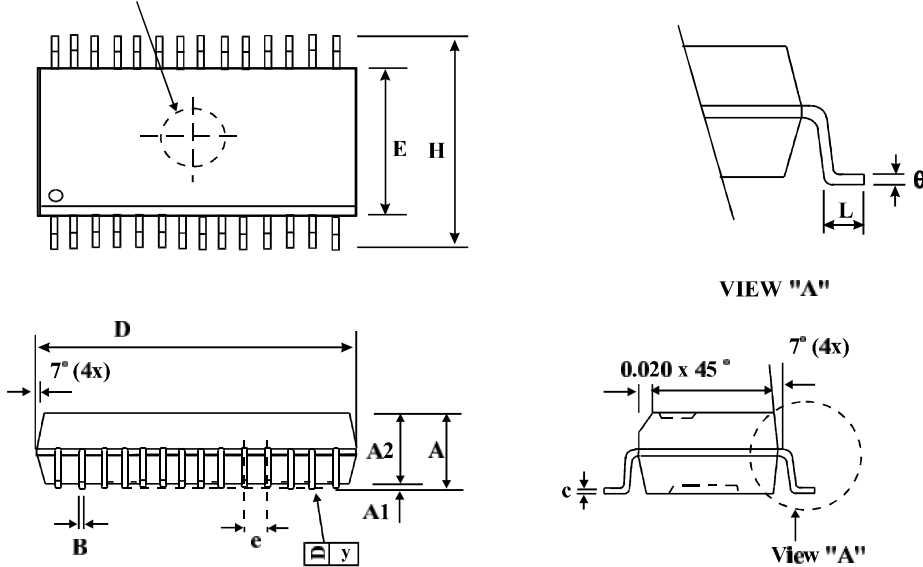

Symbol	Dimensions in Millimeter			Dimensions in Inches		
	Min	Nom	Max	Min	Nom	Max
A	2.36	2.49	2.64	0.093	0.098	0.104
A1	0.10	-	0.30	0.004	-	0.012
A2	-	2.34	-	-	0.092	-
B	0.33	0.41	0.51	0.013	0.016	0.020
C	0.23	0.25	0.30	0.009	0.010	0.012
D	17.70	17.91	18.11	0.697	0.705	0.713
E	7.39	7.49	7.59	0.291	0.295	0.299
e	-	1.27	-	-	0.050	-
H	10.01	10.31	10.64	0.394	0.406	0.419
L	0.38	0.81	1.27	0.015	0.032	0.050
y	-	-	0.10	-	-	0.004
θ	0°	-	8°	0°	-	8°

- Note:
1. Controlling Dimension: Inch
 2. Lead Frame Material: Copper 194
 3. After solder plating lead thickness will be 0.015" max.
 4. Dimension "D" does not include mold flash, protrusions or gate burrs.
 5. Dimension "E" does not include interlead or protrusions.
 6. Tolerance: ± 0.010 " unless otherwise specified.
 7. Otherwise dimension follow acceptable spec.
 8. Bottom E-Pin Indent in marked as below:

